



SOTIBLOC - Sélection 403A Aluminium

150 Nm
Ø 16-19-20-24-25

i = indice de réduction

n2 = vitesse de sortie avec moteur 4 poles (1400mn^{-1})

P = Puissance maximum en entrée avec Facteur de service = 1

M = Couple maximum en sortie avec Facteur de service = 1

B = Montage avec douille de réduction

C = Boite à bornes moteur décalée de 45°

i 1/	n1 = 1400 min ⁻¹			B5					B14					
	n2 min ⁻¹	M (Nm)	P (kW)	63	71	80	90	100	56	63	71	80	90	100
38,4	36,5	175	0,72						B-C	C				
43,69	32,0	149	0,54						B-C	C				
50,64	27,6	160	0,50						B-C	C				
53,36	26,2	138	0,41						B-C	C				
61,22	22,9	160	0,41						B-C	C				
61,9	22,6	138	0,35						B-C	C				
70,95	19,7	160	0,36						B-C	C				
73,43	19,1	175	0,38						B-C	C				
74,77	18,8	138	0,29						B-C	C				
86,66	16,1	138	0,25						B-C	C				
96,85	14,5	160	0,26						B-C	C				
102,74	13,6	180	0,28						B-C	C				
126,4	11,1	160	0,20						B-C	C				
135,69	10,3	160	0,19						B-C	C				
165,7	8,5	138	0,13						B-C	C				
177,09	7,9	160	0,14						B-C	C				
216,3	6,5	138	0,10						B-C	C				

SOTIBLOC - Dimensions 403A Aluminium

Dimensions motoréducteur

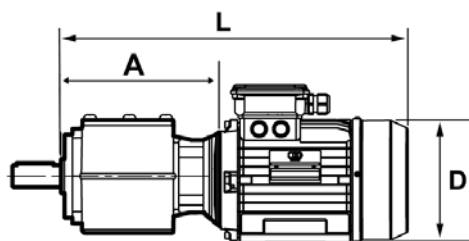

taille moteur	A	L	L frein H	L frein FHA	D
63	181.5	319	354	354	123
71	182	340	346	384	147
80	186.5	367	367	420	165
90S	190	383	383	435	181
90L	190	408	408	460	181

Diamètres d'arbres possibles

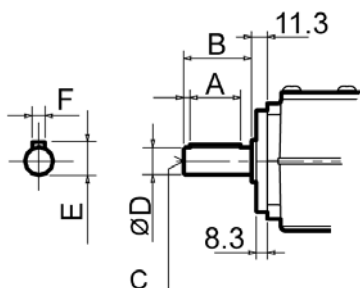

Ø axe D	A	B	C	E	F
16	30	40	M8X19	18	5
19	30	40	M8X19	21.5	6
20	30	40	M8X19	22.5	6
24	40	50	M8X19	26	8
25	40	50	M8X19	27	8



SOTIBLOC - Dimensions 403A Aluminium

Dimensions fixation par pattes

Kg 6.3

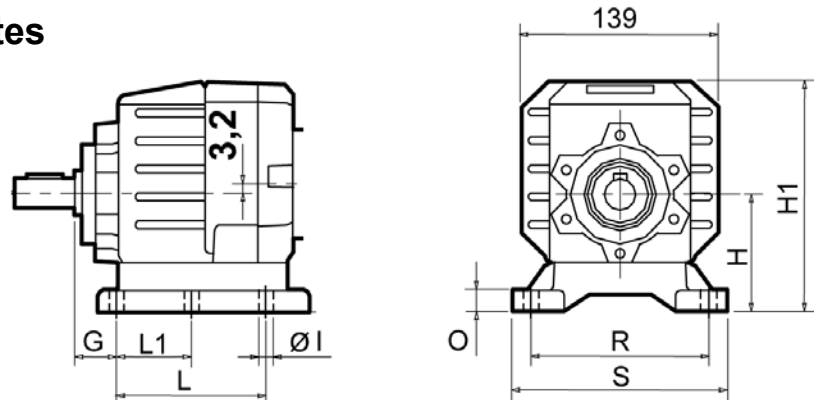

REF marché	REF PATTES	H	L	R	L1	G	S	H1	O	I
102	PAT-B1	85	87	110	50	18	130	167	15	9
202/3	PAT-B2	100	107.5	130	60	18	155	182	17	11
17	PAT-S1	75	90+20	110	50	18	145	155	15	9
27 - 37	PAT-S2	90	130	110		25	145	172	20	9
020 - 021	PAT-H1	80	90	110		18	135	162	14	9
022-023	PAT-H2	100	115	110		25	145	182	20	9
2002/3	PAT-E0	75	85	110		18	150	157	5	10
2102/3	PAT-E1	80	165	110		16	165	162	6	12
42/3	PAT-M1	80	85	110-120		25	145	162	15	9
R1	MF352	80	60	116		21	150	162	13	11
R2	MF402	100	72	145		24	182	182	6	11

Dimensions fixation par trous taraudés série " MN "

Kg 5.9

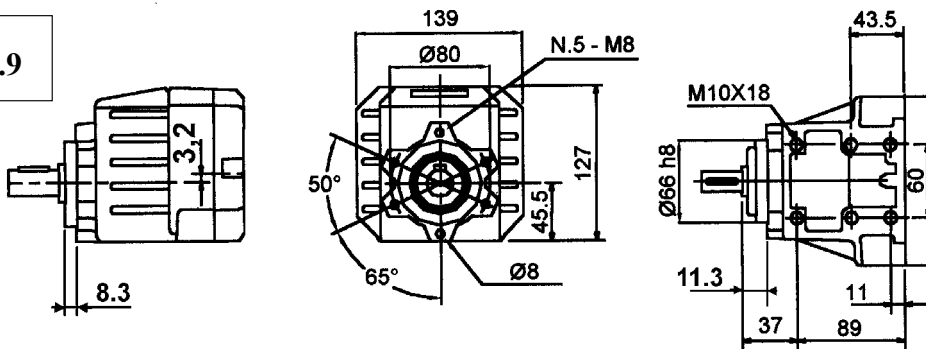

Dimensions fixation par bride à trous lisses série " MX "

type	MXA	MXB	MXC	MXD
a1	120	140	160	200
b1	80	95	110	130
e1	100	115	130	165
c1	11.5	11.5	11.5	11.5
f1	3	3	3.5	3.5
S1	9	9	9	11

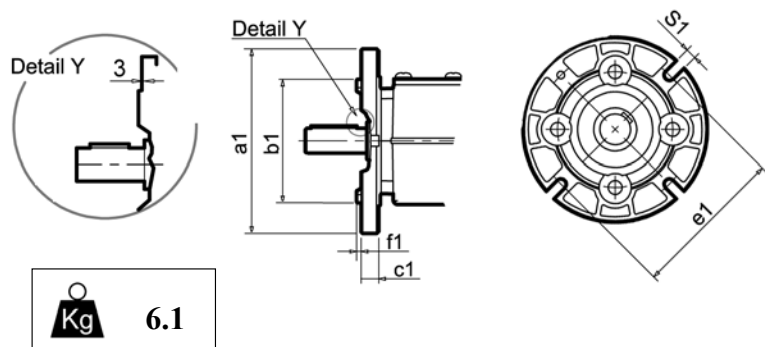

Kg 6.1