

| Taille réducteur | Iec moteur | Rapports possibles | | | | | | | | | | |
|------------------|------------|--------------------|----|----|----|----|----|----|----|----|----|-----|
| | | 7 | 10 | 15 | 20 | 25 | 30 | 40 | 50 | 60 | 80 | 100 |
| 25 | 56 | x | x | x | x | x | x | x | x | x | | |
| 30 | 56 | x | x | x | x | x | x | x | x | x | x | |
| | 63 | x | x | x | x | x | x | x | x | | | |
| | 56 | B5 | B5 | B5 | B5 | B5 | B5 | B5 | B5 | B5 | B5 | B5 |
| 40 | 63 | x | x | x | x | x | x | x | x | x | x | x |
| | 71 | x | x | x | x | x | x | x | | | | |
| | 63 | B5 | B5 | B5 | B5 | B5 | B5 | B5 | B5 | B5 | B5 | B5 |
| 50 | 71 | x | x | x | x | x | x | x | x | x | x | |
| | 80 | x | x | x | x | x | x | | | | | |
| | 71 | x | x | x | x | x | x | x | x | x | x | x |
| 63 | 80 | x | x | x | x | x | x | x | x | | | |
| | 90 | x | x | x | x | x | x | | | | | |
| | 71 | B5 | B5 | B5 | B5 | B5 | B5 | B5 | B5 | B5 | B5 | B5 |
| 75 | 80 | x | x | x | x | x | x | x | x | x | x | x |
| | 90 | x | x | x | x | x | x | x | | | | |
| | 100/112 | x | x | x | | | | | | | | |
| | 80 | x | x | x | x | x | x | x | x | x | x | x |
| 90 | 90 | x | x | x | x | x | x | x | x | | | |
| | 100/112 | x | x | x | x | x | x | | | | | |
| | 80 | B5 | B5 | B5 | B5 | B5 | B5 | B5 | B5 | B5 | B5 | B5 |
| 110 | 90 | B5 | B5 | B5 | B5 | B5 | B5 | B5 | B5 | B5 | B5 | B5 |
| | 100/112 | x | x | x | x | x | x | x | x | | | |
| | 132 | x | x | x | x | | | | | | | |
| | 90 | B5 | B5 | B5 | B5 | B5 | B5 | B5 | B5 | B5 | B5 | B5 |
| 130 | 100/112 | B5 | B5 | B5 | B5 | B5 | B5 | B5 | B5 | B5 | B5 | B5 |
| | 132 | B5 | B5 | B5 | B5 | B5 | B5 | | | | | |
| | 100/112 | B5 | B5 | B5 | B5 | B5 | B5 | B5 | B5 | B5 | B5 | B5 |
| 150 | 132 | B5 | B5 | B5 | B5 | B5 | B5 | B5 | B5 | | | |
| | 160 | B5 | B5 | B5 | B5 | B5 | | | | | | |

X Montages B5 et B14 possible
5 Montage B5 seul possible
14 Montage B14 seul possible

B14

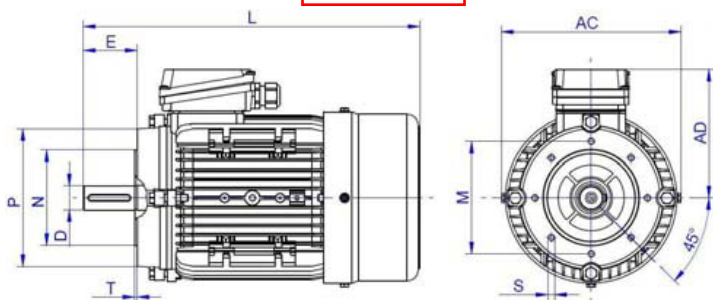

B5

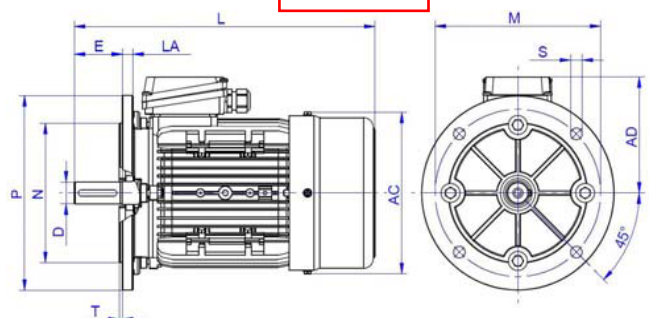

| Taille | B14 | | | | | B5 | | | | | | | | | | | | |
|--------|-----|-----|-----|-----|-----|-----|-----|-----|-----|----|----|----|----|------|-----|-----|-----|-----|
| | P | N | M | T | S | P | N | M | T | S | D | F | FB | GA | L | AD | AC | DB |
| M56 | 80 | 50 | 65 | 2,5 | M5 | 120 | 80 | 100 | 3 | 7 | 9 | 3 | 14 | 10,2 | 194 | 96 | 114 | M3 |
| M63 | 90 | 60 | 75 | 2,5 | M5 | 140 | 95 | 115 | 3 | 10 | 11 | 4 | 15 | 12,5 | 218 | 99 | 130 | M4 |
| M71 | 105 | 70 | 85 | 2,5 | M6 | 160 | 110 | 130 | 3,5 | 10 | 14 | 5 | 20 | 16 | 251 | 110 | 151 | M5 |
| M80 | 120 | 80 | 100 | 3 | M6 | 200 | 130 | 165 | 3,5 | 12 | 19 | 6 | 30 | 21,5 | 285 | 132 | 168 | M6 |
| M90S | 140 | 95 | 115 | 3 | M8 | 200 | 130 | 165 | 3,5 | 12 | 24 | 8 | 40 | 27 | 334 | 139 | 181 | M8 |
| M90L | 140 | 95 | 115 | 3 | M8 | 200 | 130 | 165 | 3,5 | 12 | 24 | 8 | 40 | 27 | 334 | 139 | 181 | M8 |
| M100L | 160 | 110 | 130 | 3,5 | M8 | 250 | 180 | 215 | 4 | 15 | 28 | 8 | 50 | 31 | 382 | 148 | 206 | M10 |
| M112M | 160 | 110 | 130 | 3,5 | M8 | 250 | 180 | 215 | 4 | 15 | 28 | 8 | 50 | 31 | 422 | 168 | 228 | M10 |
| M132S | 200 | 130 | 165 | 4 | M10 | 300 | 230 | 265 | 4 | 15 | 38 | 10 | 70 | 41 | 503 | 185 | 272 | M12 |
| M132M | 200 | 130 | 165 | 4 | M10 | 300 | 230 | 265 | 4 | 15 | 38 | 10 | 70 | 41 | 503 | 185 | 272 | M12 |