

Riduttori con rinvio angolare 90°

Right angle gearboxes

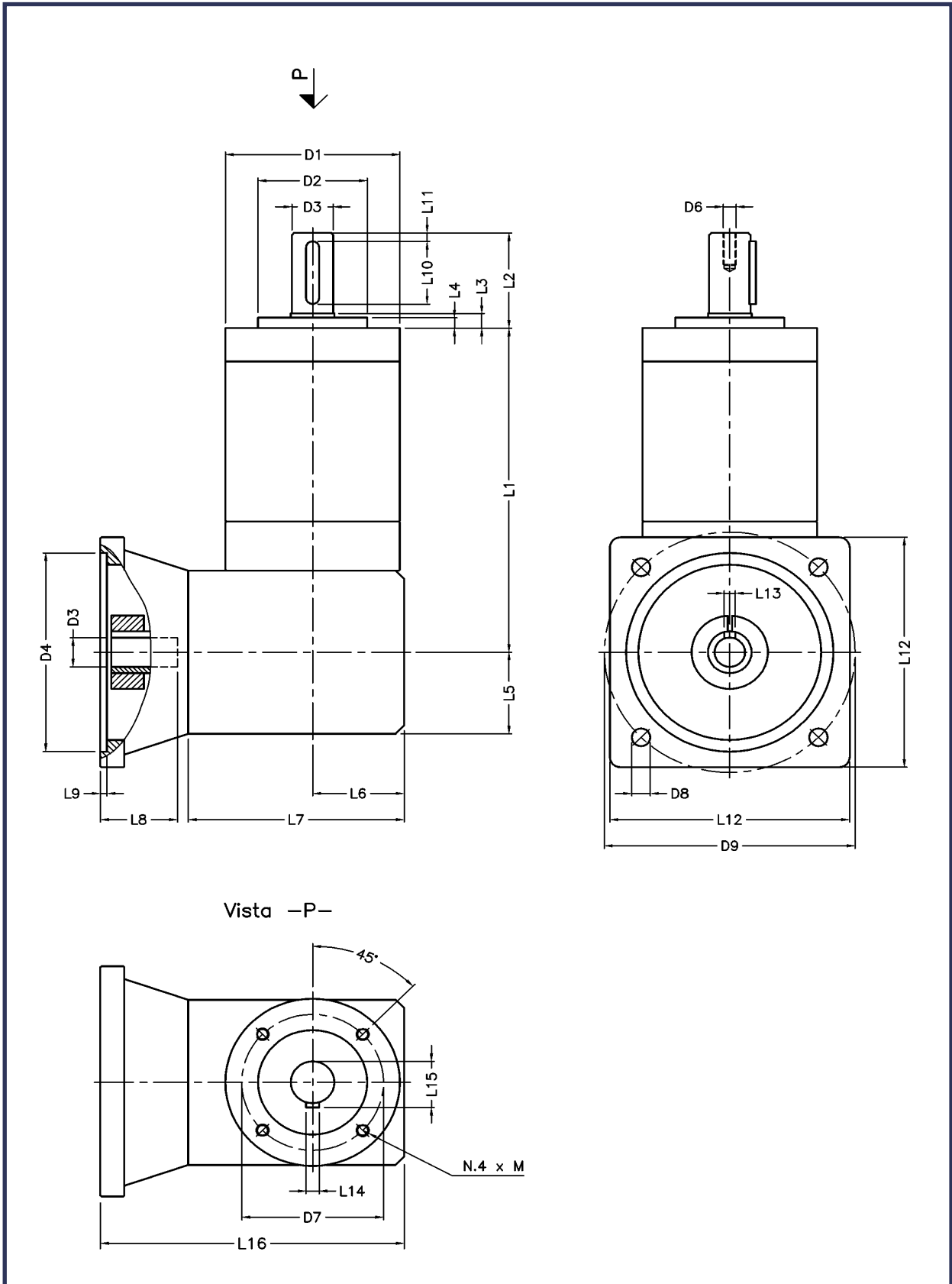

Dimensioni Riduttore - Gear dimensions															
Quote	RE55			RE63			RE80			RE105			RE130		
	1ST	2ST	3ST	1ST	2ST	3ST	1ST	2ST	3ST	1ST	2ST	3ST	1ST	2ST	3ST
D1	55			63			80			105			130		
D2	32			40			50			70			80		
D3	12			14			19			25			32		
D4							(1)								
D6 (2)	M4			M5			M6			M8			M10		
D7	40			52			65			85			110		
D8							(1)								
D9							(1)								
L1	88	103	118	96	111	126	131,5	155	178,5	124	175,5	209	184	220,5	257
L2	25			36			46			56,5			70		
L3	2,5			3			5			5			7		
L4	--			6			7			7,5			15		
L5	27,5			27,5			39			39			60		
L6	27,5			27,5			42			42			60		
L7	63,5			63,5			99			99			12		
L9							(1)								
L10	16			20			30			35			50		
L11	2,5			5			4			5			3		
L12							(1)								
L14	4			5			6			8			10		
L15	13,5			16			21,5			28			35		
M	M5			M5			M6			M8			M12		

(1) Le dimensioni dipendono dal motore utilizzato
(Fare riferimento alle flangiate dei riduttori epicicloidali
pag. 13-30)

(1) The dimensions depend on the type of motor
to be mounted (See gearboxes data pag. 13-30)

(2) Esecuzione su Richiesta

(2) Available on demand

DIMENSIONI FLANGIATURA - COUPLING DIMENSIONS															
RA55				RA63				RA80 - RA105				RA130			
D5 ^{H6}	L8	L16	L13	D5 ^{H6}	L8	L16	L13	D5 ^{H6}	L8	L16	L13	D5 ^{H6}	L8	L16	L13
8	25	92	3	8	25	92	3	9	25	134	3	14	30	180	5
9	25	92	3	9	25	92	3	9,52	32	134	3	19	40	180	6
9,52	32	94	3	9,52	32	94	3	11	30	134	4	22	50	190	6
11	25	92	4	11	25	92	4	12	30	134	4	24	50	190	8
12	30	92	4	12	30	92	4	12,7	32	134	5	28	60	200	8
12,7	32	94	5	12,7	32	94	5	14	30	134	5	32	60	200	10
--	--	--	--	14	30	92	5	16	40	134	5	35	80	220	10
--	--	--	--	--	--	--	--	19	40	134	6	--	--	--	--
--	--	--	--	--	--	--	--	24	50	145,6	8	--	--	--	--

Per i dati tecnici relativi al riduttore, consultare le
pagine precedenti (da pag. 13)

For the technical specifications of the
gearboxes, see the previous pages (from pag. 13)