

Schémas de branchement moteurs triphasés à deux vitesses

Enroulement unique tension unique

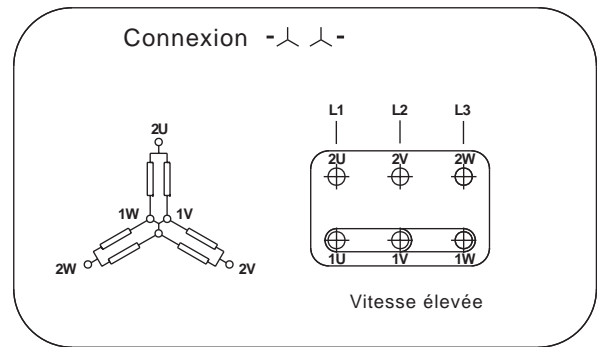

Démarrage Y/Δ

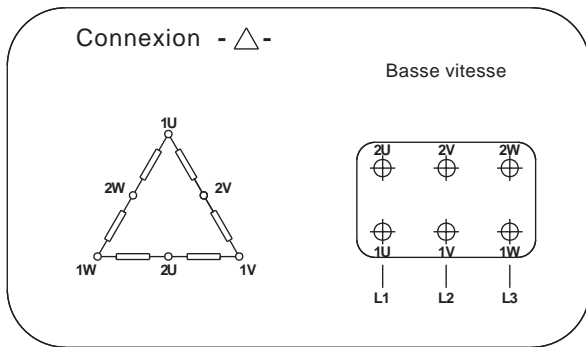
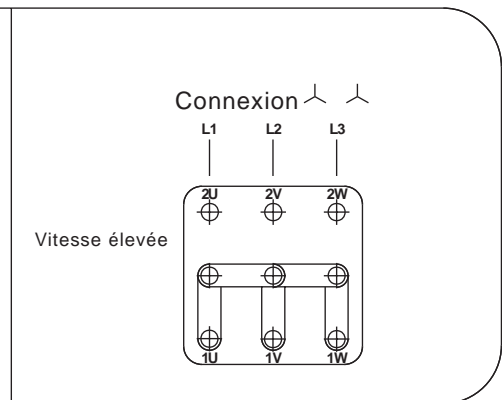
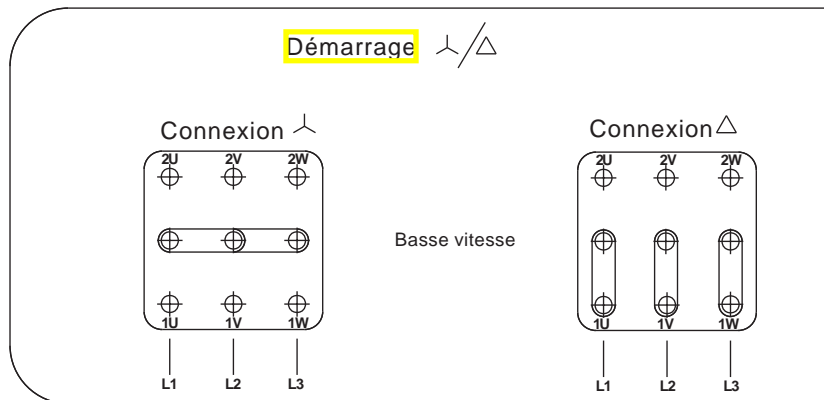

Double enroulement tension unique

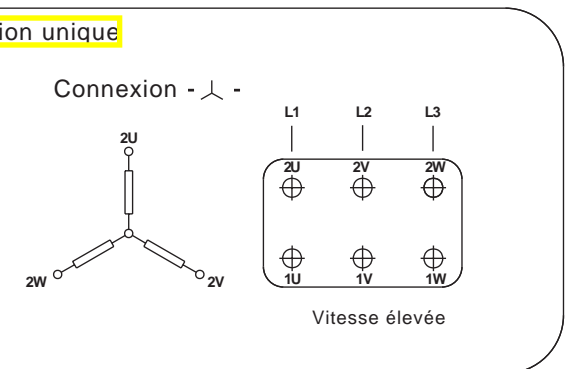
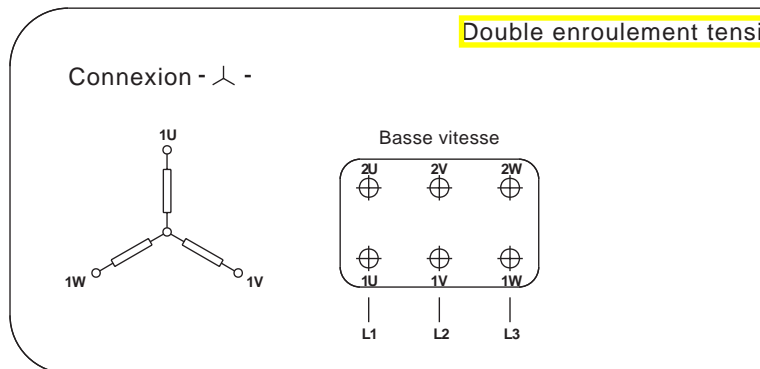

Double enroulement double tension

