

**MO TO REDUCTEUR
DOUBLE ROUE ET VIS**

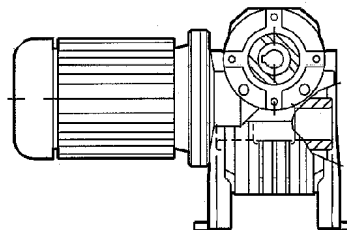

DIMENSIONS SERIE "B & S" (PATTES)

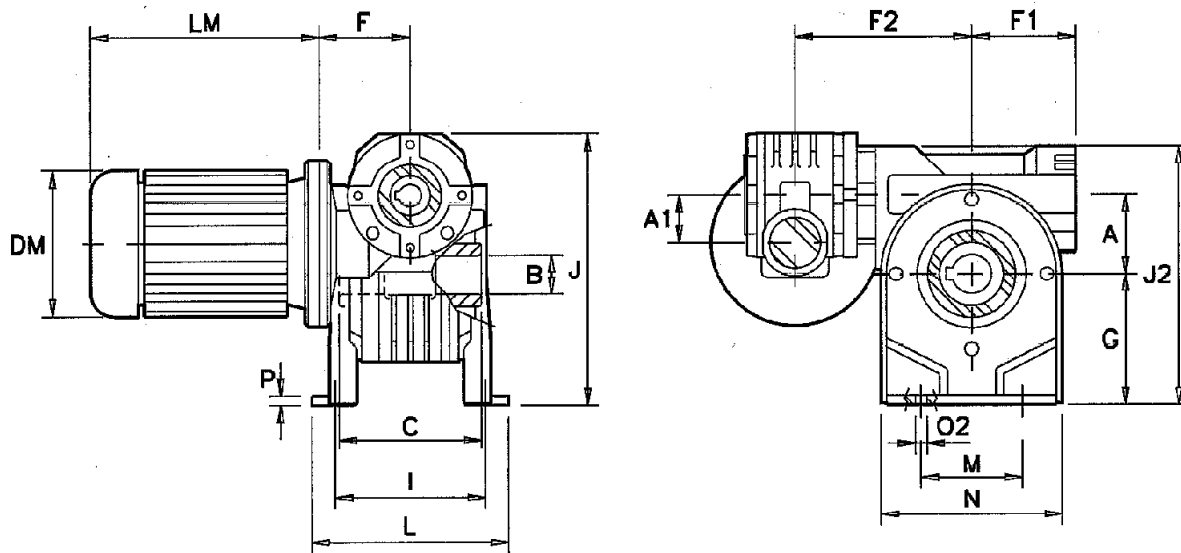

C1

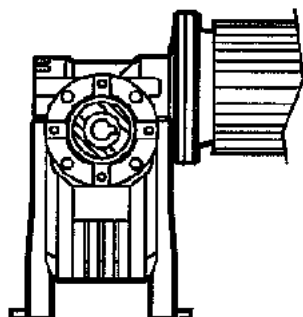

C2

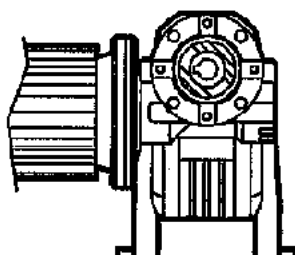

C3

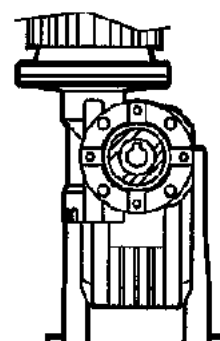

MOTOREDUCTEUR DOUBLE ROUE ET VIS

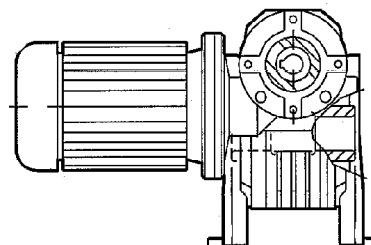

DIMENSIONS SERIE "B" (PATTES)

| | 303 | 453 | 503 | 633 | 734 | 854 | 115 |
|-----|-------|-------|--------|---------|-----|-------|-----|
| A | 30 | 45 | 50 | 63 | 63 | 85 | 110 |
| A 1 | 30 | 30 | 30 | 30 | 45 | 45 | 50 |
| B | 14 | 18 | 25 | 25 | 28 | 35 | 42 |
| C | 55 | 65 | 81 | 120 | 120 | 135 | 155 |
| F | 62,5 | 63 | 63 | 63 | 74 | 74 | 148 |
| F1 | 46 | 55 | 65 | 79 | 79 | 98 | 125 |
| F2 | 92,5 | 105,5 | 110 | 141 | 146 | 171,7 | 201 |
| G | 55 | 72 | 82 | 100 | 115 | 142 | 170 |
| I | 65-66 | 80-81 | 98-100 | 110-111 | 115 | 145 | 180 |
| J | 124 | 141 | 171 | 202 | 227 | 276 | 266 |
| J 2 | 106 | 144 | 163 | 200 | 215 | 280 | 340 |
| L | 87 | 100 | 123 | 144 | 142 | 182 | 224 |
| M | 50 | 50-52 | 63-65 | 95 | 120 | 140 | 200 |
| N | 78 | 98 | 113 | 133 | 156 | 180 | 240 |
| O2 | 6,5 | 10,5 | 10,5 | 10,5 | 11 | 105 | 13 |
| P | 3 | 3 | 3,5 | 4 | 12 | 5 | 22 |

| RÉFÉRENCE | PAT30 | PAT45 | PAT50 | PAT63 | PAT70 | PAT85 | PAT110 |
|-----------|-------|-------|-------|-------|-------|-------|--------|
| LA PATTE | 4,67 | 6,83 | 11,33 | 12,33 | 16,67 | 22,33 | 43,33 |

DIMENSIONS SERIE "S" (PATTES)

| | | | | | | | |
|-----|------|-------------|-------|-----------|-------------|-------------|-------------|
| B | 14 | 19 (20) | 24 | 25 (25,4) | 28 (30) | 35 (38) | 42 (45) |
| b | 5 | 6 (6) | 8 | 8 | 8 (8) | 10 (10) | 12 (14) |
| F | 62,5 | 74 | 81,5 | 99,5 | 99,5 | 124 | 148 |
| G | 52 | 71 | 85 | - | - | 142 | 172 |
| I | 66 | 84 | 96 | - | - | 145 | 160 |
| J | 91 | 121 | 139,5 | - | - | 236,5 | - |
| J 2 | 103 | 143 | 166 | - | - | 280 | 342 |
| L | 87 | 100 | 114 | - | - | 182 | 190 |
| M | 52 | 70 | 85 | - | - | 140 | 200 |
| N | 90 | 90 | 110 | - | - | 180 | 240 |
| O4 | 6,5 | 8 | 10 | - | - | 10,5 | 14 |
| P | 3 | 8 | 10 | - | - | 5 | 18 |
| t 1 | 16,3 | 20,8 (21,8) | 28,3 | 28,3 | 31,3 (32,3) | 38,3 (40,2) | 45,3 (48,8) |

| RÉFÉRENCE | PATS30 | PATS45 | PATS50 | - | - | PATS85 | PATS110 |
|-----------|--------|--------|--------|---|---|--------|---------|
| LA PATTE | 4,67 | 11,33 | 16 | - | - | 22,3 | 58,33 |

MOTOREDUCTEUR DOUBLE ROUE ET VIS

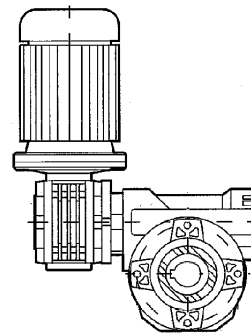

DIMENSIONS SERIE "B" (BRIDE)

| O* | |
|--------------------------|--|
| 453 503 | |
| 633 6A3 634 6A4 | |
| 854 | |

M... \FB

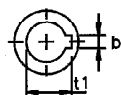
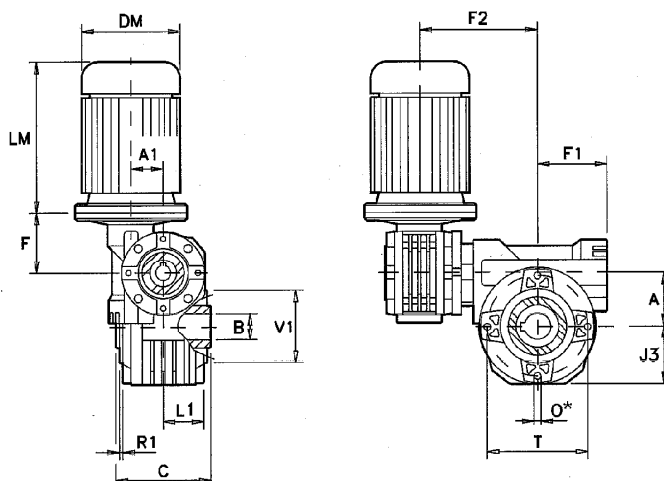

M... \FC

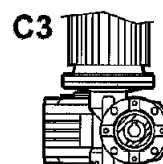
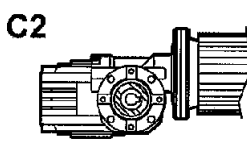
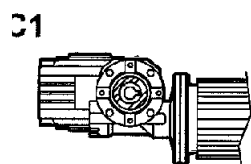
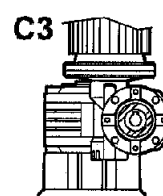
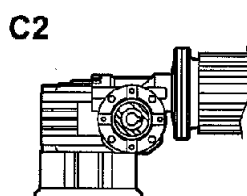
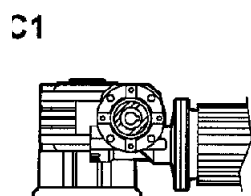
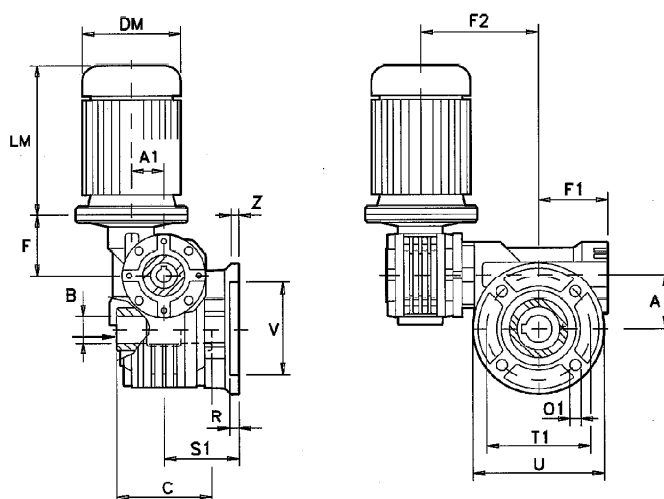

MOTOREDUCTEUR DOUBLE ROUE ET VIS

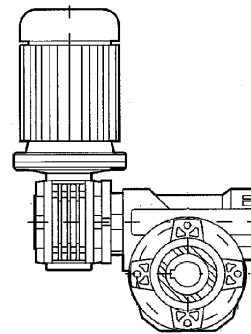

DIMENSIONS SERIE "S" (BRIDE)

| O* | |
|--------------------------|--|
| 453 503 | |
| 633 6A3 634 6A4 | |
| 854 | |

M... \FB

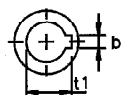
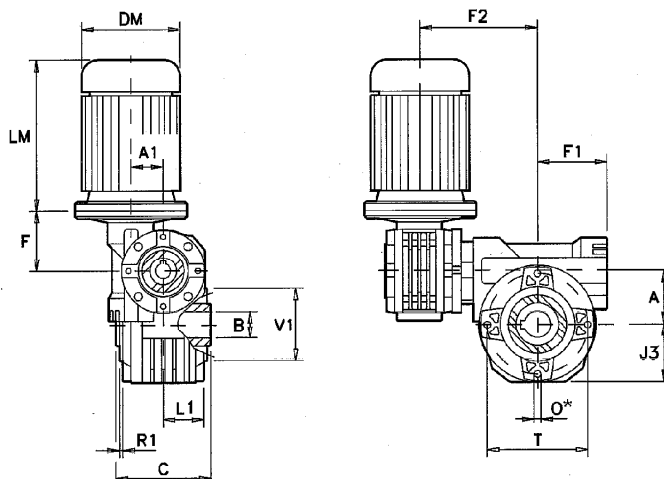

M... \FC

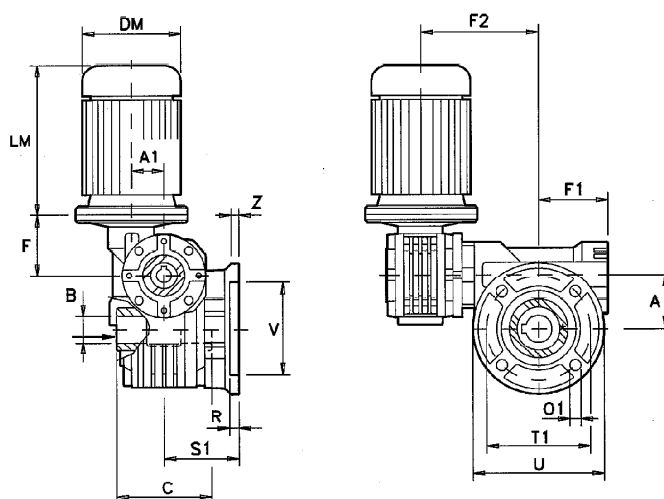

C1

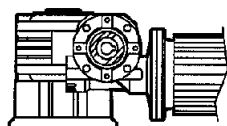

C2

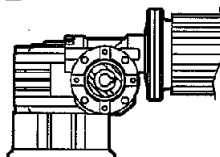

C3

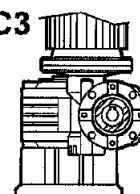

C1

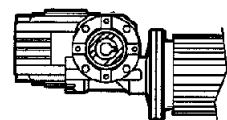

C2

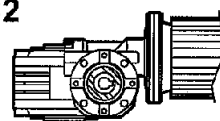

C3

