

**MO TO REDUCTEUR
ENGRENAGES + ROUE ET VIS**

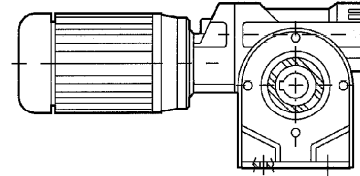

DIMENSIONS SERIE "B&S" (PATTES)

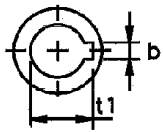

M... \PA

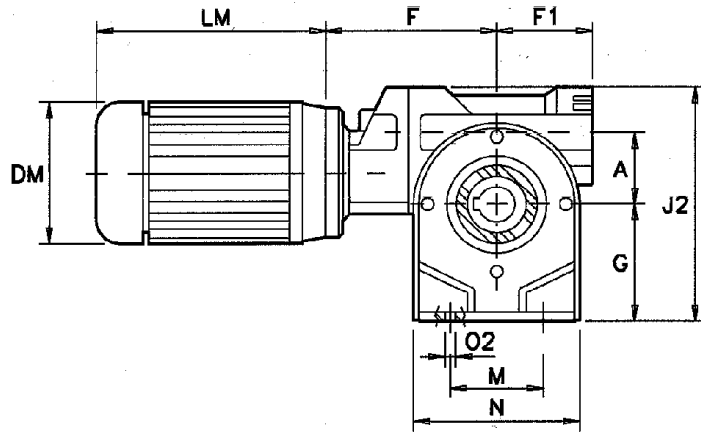
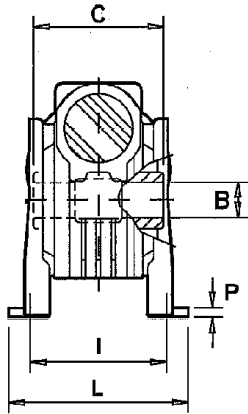

M... \PB

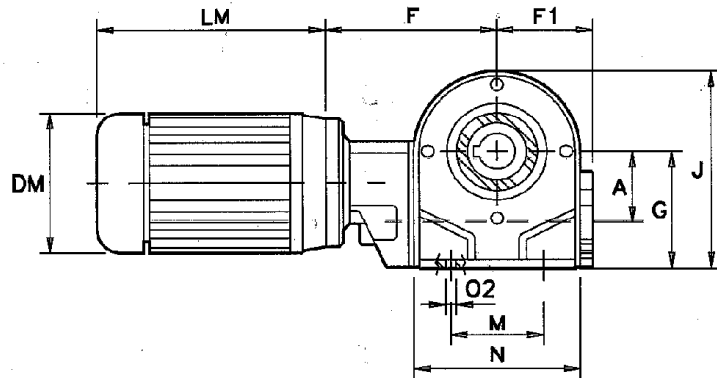
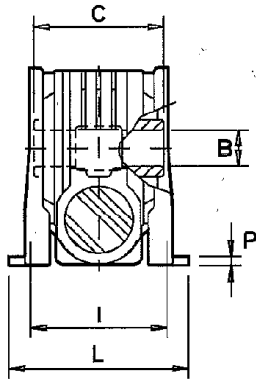

M... \PV

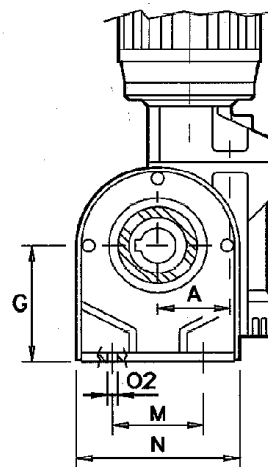
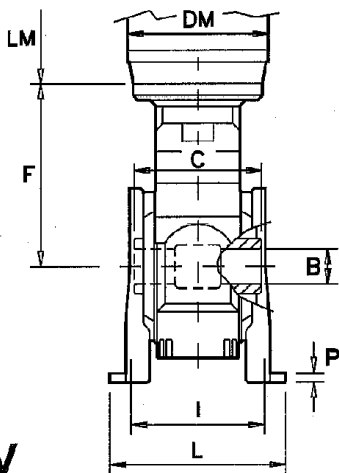

MOTOREDUCTEUR ENGRENAGES & ROUE ET VIS

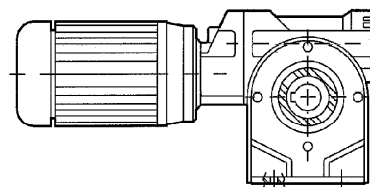

DIMENSIONS SERIE "B" (PATTES)

| | PP45 | PP50 | PP63 | PP70 | PP85 | PP110 |
|--------|----------|----------|-----------|-----------|-----------|-----------|
| A | 45 | 50 | 63 | 63 | 85 | 110 |
| B (H7) | 18 | 25 | 25 | 28 | 35 | 42 |
| b | 6 | 8 | 8 | 8 | 10 | 12 |
| C | 65 | 81 | 120 | 120 | 135 | 155 |
| F | 136 | 141 | 178,2 | 178,2 | 196,5 | 239 |
| F1 | 55 | 65 | 79 | 79 | 98 | 125 |
| G | 72(+0.2) | 82(+0.2) | 100(+0.2) | 115(+0.2) | 142(+0.2) | 170(+0.2) |
| I | 80-81 | 98-100 | 110-111 | 115 | 145 | 180 |
| J | 121 | 138.5 | 170 | 170 | 236.5 | 266 |
| J1 | 72 | 81 | 100 | 100 | 138 | 170 |
| J2 | 144 | 163 | 200 | 215 | 280 | 340 |
| L | 100 | 123 | 144 | 142 | 182 | 224 |
| M | 50-52 | 63-65 | 95 | 120 | 140 | 200 |
| N | 98 | 113 | 133 | 156 | 180 | 240 |
| O2 | 10.5 | 10.5 | 10.5 | 11 | 10.5 | 13 |
| P | 3 | 3.5 | 4 | 12 | 5 | 22 |
| t1 | 20,8 | 28,3 | 28,3 | 31,3 | 38,3 | 45,3 |

| RÉFÉRENCE | PAT45 | PAT50 | PAT63 | PAT70 | PAT85 | PAT110 |
|-----------|-------|-------|-------|-------|-------|--------|
| LA PATTE | 6,83 | 11,33 | 12,33 | 16,67 | 22,33 | 43,33 |

DIMENSIONS SERIE "S" (PATTES)

| | | | | | | |
|----|-------------|-------|-----------|-------------|-------------|-------------|
| B | 19 (20) | 24 | 25 (25,4) | 28 (30) | 35 (38) | 42 (45) |
| b | 6 (6) | 8 | 8 | 8 (8) | 10 (10) | 12 (14) |
| F | 136 | 141 | 178,2 | 178,2 | 196,5 | 239 |
| G | 71 | 85 | - | - | 142 | 172 |
| I | 84 | 96 | - | - | 145 | 160 |
| J | 121 | 139,5 | - | - | 236,5 | - |
| J2 | 143 | 166 | - | - | 280 | 342 |
| L | 100 | 114 | - | - | 182 | 190 |
| M | 70 | 85 | - | - | 140 | 200 |
| N | 90 | 110 | - | - | 180 | 240 |
| O4 | 8 | 10 | - | - | 10,5 | 14 |
| P | 8 | 10 | - | - | 5 | 18 |
| t1 | 20,8 (21,8) | 28,3 | 28,3 | 31,3 (32,3) | 38,3 (40,2) | 45,3 (48,8) |

| RÉFÉRENCE | PATS45 | PATS50 | - | - | PATS85 | PATS110 |
|-----------|--------|--------|---|---|--------|---------|
| LA PATTE | 11,33 | 16 | - | - | 22,3 | 58,33 |

MO TO REDUCTEUR ENGRENAGES + ROUE ET VIS

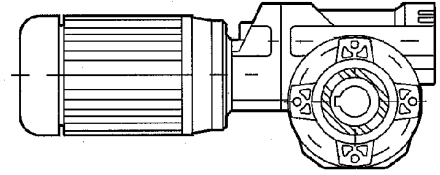

DIMENSIONS SERIE "B" (BRIDE)

| O* | |
|-------------------|--|
| P45 P50 | |
| P63 P6A P10 | |
| P85 | |

M... \FB

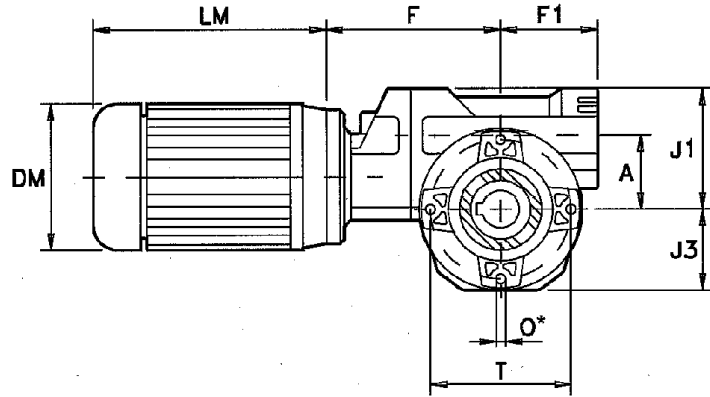
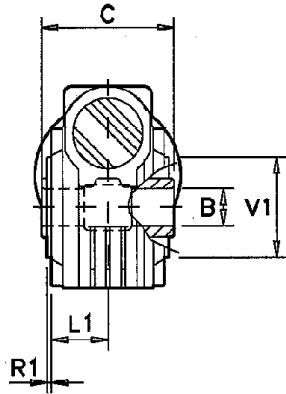

M... \FC

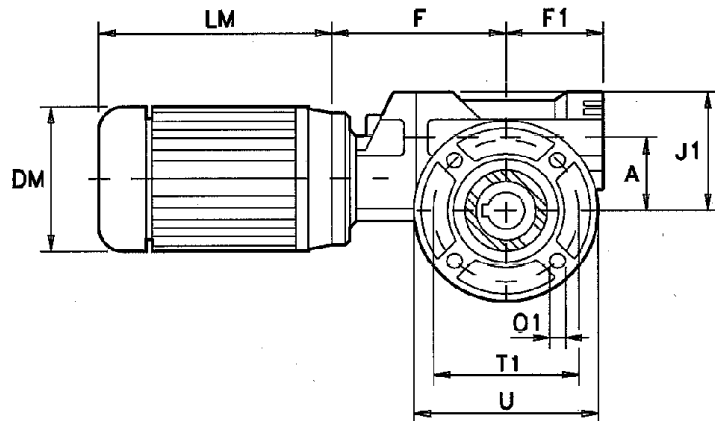
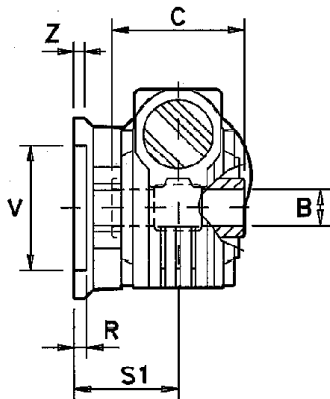

M... \FL

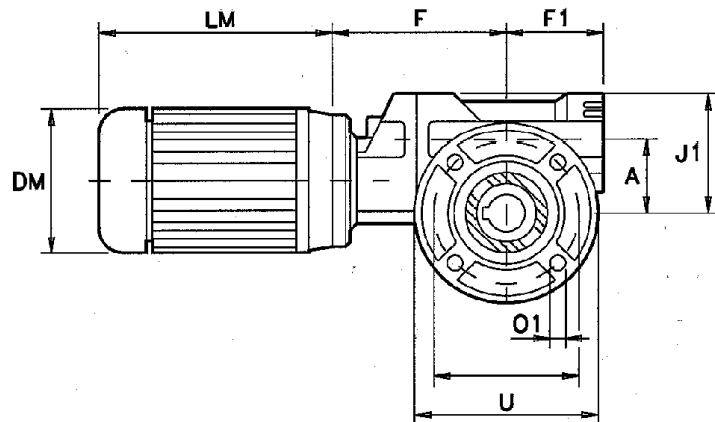
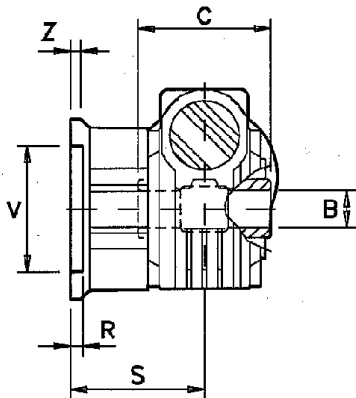

MO TO REDUCTEUR ENGRENAGES & ROUE ET VIS

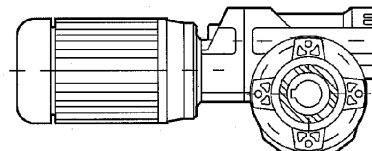

DIMENSIONS SERIE "B" (BRIDE)

| | | PP45 | PP50 | PP63 | PP70 | PP85 | PP110 |
|------------|---------|---------|--------|---------|---------|----------|----------|
| FB | A | 45 | 50 | 63 | 63 | 85 | 110 |
| | B (H7) | 18 | 25 | 25 | 28 | 35 | 42 |
| | b | 6 | 8 | 8 | 8 | 10 | 12 |
| | C | 65 | 81 | 120 | 120 | 135 | 155 |
| | F | 136 | 141 | 178,2 | 178,2 | 196,5 | 239 |
| | F1 | 55 | 65 | 79 | 79 | 98 | 125 |
| | J1 | 72 | 81 | 100 | 100 | 138 | 170 |
| | t1 | 20,8 | 28,3 | 28,3 | 31,3 | 38,3 | 45,3 |
| FC | J3 | 49 | 54,5 | 70 | 70 | 94,5 | 120 |
| | L1 | 35 | 38 | 45 | 45 | 64 | 74 |
| | O | 4-M6*14 | 4-M6*9 | 8-M8*17 | 8-M8*17 | 4-M10*18 | 8-M12*30 |
| | R1 | 2 | 3 | 5 | 5 | 3,5 | 3,5 |
| | T | 65 | 94 | 90 | 90 | 130 | 165 |
| | V1 | 50 | 68 | 75 | 75 | 110 | 130 |
| FA | O1 | 8,5 | 10,5 | 10,5 | 13 | 13 | 13 |
| | R | 9 | 9 | 7 | 7 | 10 | 11 |
| | S1 | 60,5 | 85 | 86 | 85 | 108 | 131,5 |
| | S (FL) | 90,5 | 114,5 | 116 | 111 | 148,5 | 179,5 |
| | T1 | 87 | 90 | 150 | 165 | 176 | 230 |
| | U | 110 | 123 | 175 | 200 | 205 | 270 |
| | V | 60 | 70 | 115 | 130 | 152 | 170 |
| | Z | 9 | 12 | 13 | 13 | 16 | 16,5 |
| FD | O1 | 9 | 10 | 11 | 11 | 13 | 15 |
| | R | 3 | 4 | 5 | 5 | 5 | 5 |
| | S1 | 51,5 | 66,5 | 82 | 84,5 | 106,5 | 130 |
| | S (FLA) | 81,5 | 96 | 112 | 110,5 | - | 150 |
| | T1 | 100 | 115 | 130 | 130 | 165 | 215 |
| | U | 120 | 140 | 160 | 160 | 200 | 250 |
| | V | 80 | 95 | 110 | 110 | 130 | 180 |
| | Z | 8 | 10 | 13,5 | 13,5 | 13 | 18 |
| FLD | O1 | 9 | 10 | 13 | 13 | 11,5 | 15 |
| | R | 4 | 4 | 7 | 7 | 5 | 5 |
| | S1 | 73,5 | 83,5 | 102 | 85 | 117,5 | 130 |
| | S (FLD) | 103,5 | 113 | 132 | 111 | - | 150 |
| | T1 | 115 | 130 | 165 | 165 | 165 | 215 |
| | U | 140 | 160 | 200 | 200 | 200 | 250 |
| | V | 95 | 110 | 130 | 130 | 130 | 180 |
| | Z | 11 | 11 | 13 | 13 | 13 | 18 |

**PRIX DES KITS BRIDES (A RAJOUTER AU PRIX DE BASE "FB")
PRIX EN EURO PRIX EN EURO**

| | | | | | | |
|------------|--------------|--------------|--------------|--------------|--------------|--------------|
| FC | 13,33 | 18,67 | 24 | 28 | 44,33 | 58,33 |
| FL | 31,33 | 36,33 | 42 | 46 | 64 | 67,33 |
| FA | 16,33 | 18 | 30,67 | 30,67 | 66,67 | 70 |
| FLA | 34,33 | 36 | 47,33 | 47,33 | 56,67 | 76,67 |
| FD | 16,33 | 22,67 | 40 | 40 | 52,33 | 71,67 |
| FLD | 34,33 | 40,67 | 50,33 | 50,33 | 63,33 | 83,33 |

MO TO REDUCTEUR ENGRENAGES + ROUE ET VIS

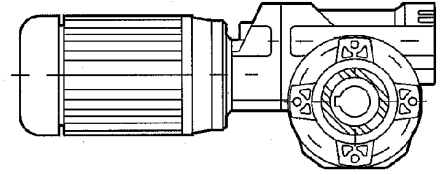

DIMENSIONS SERIE "S" (BRIDE)

| O* | |
|-------------------|--|
| P45 P50 | |
| P63 P6A P10 | |
| P85 | |

M... \FB

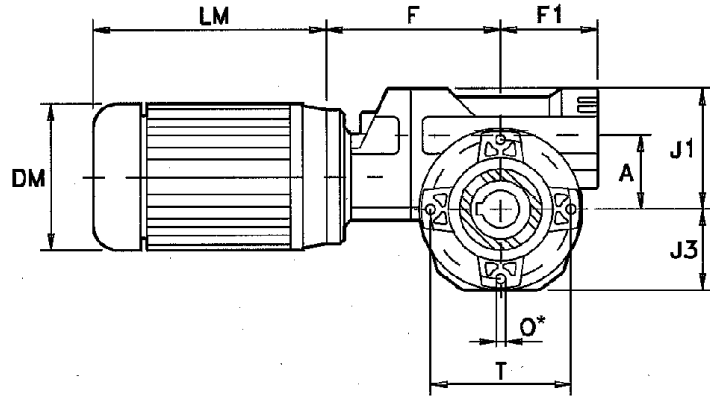
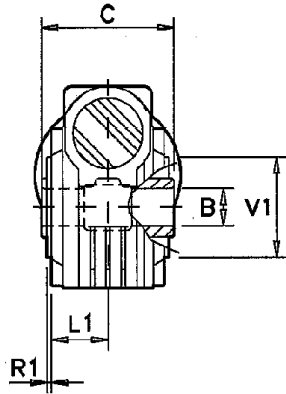

M... \FC

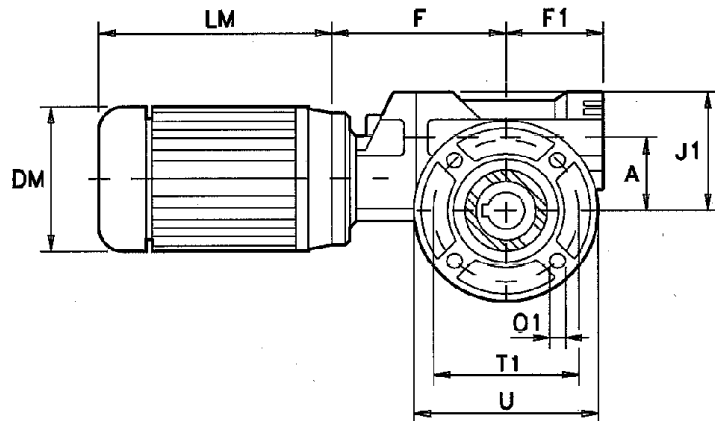
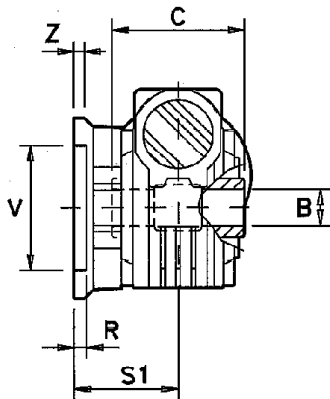

M... \FL

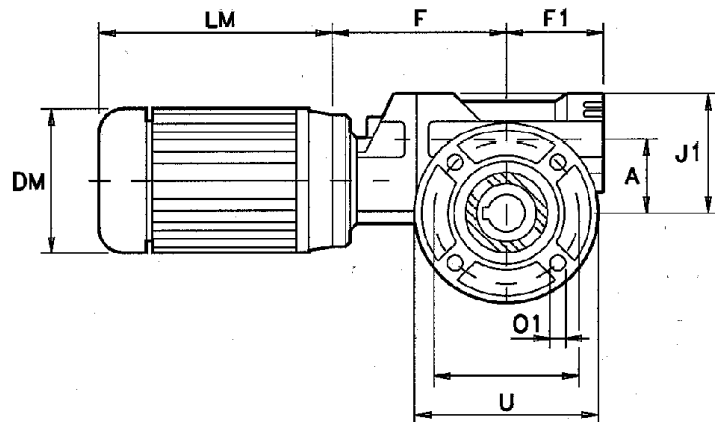
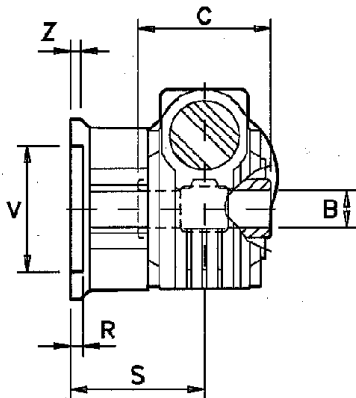

MOTOREDUCTEUR ENGRENAGES ROUE ET VIS

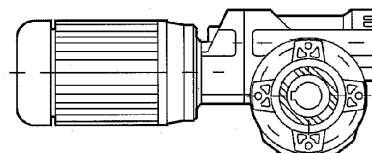

DIMENSIONS SERIE "S" (BRIDE)

| | | PP45 | PP50 | PP63 | PP70 | PP85 | PP110 | |
|-----------|---------------|---------|-------------|---------|---------|-------------|-------------|-------------|
| A | A | 45 | 50 | 63 | 63 | 85 | 110 | |
| | B (H7) | B | 19 (20) | 24 | 25 | 28 (30) | 35 (38) | 42 (45) |
| | | b | 6 (6) | 8 | 8 | 8 (8) | 10 (10) | 12 (14) |
| | C | C | 65 | 81 | 120 | 120 | 135 | 155 |
| | | F | 136 | 141 | 178,2 | 178,2 | 196,5 | 239 |
| | F1 | F1 | 55 | 65 | 79 | 79 | 98 | 125 |
| | | J1 | 72 | 81 | 100 | 100 | 138 | 170 |
| | t1 | t1 | 20,8 (21,8) | 28,3 | 28,3 | 31,3 (32,3) | 38,3 (40,2) | 45,3 (48,8) |
| | | | | | | | | |
| FB | J3 | 49 | 54,5 | 70 | 70 | 94,5 | 120 | |
| | L1 | 35 | 38 | 45 | 45 | 64 | 74 | |
| | O | 4-M6*14 | 4-M6*9 | 8-M8*17 | 8-M8*17 | 4-M10*18 | 8-M12*30 | |
| | R1 | 2 | 3 | 5 | 5 | 3,5 | 3,5 | |
| | T | 65 | 94 | 90 | 90 | 130 | 165 | |
| | V1 | 50 | 68 | 75 | 75 | 110 | 130 | |
| FC | O1 | 8,5 | 10,5 | 10,5 | 13 | 13 | 13 | |
| | R | 9 | 9 | 7 | 7 | 10 | 11 | |
| | S1 | S1 | 60,5 | 85 | 86 | 85 | 108 | 131,5 |
| | | S (FL) | 90,5 | 114,5 | 116 | 111 | 148,5 | 179,5 |
| | T1 | 87 | 90 | 150 | 165 | 176 | 230 | |
| | U | 110 | 123 | 175 | 200 | 205 | 270 | |
| | V | 60 | 70 | 115 | 130 | 152 | 170 | |
| | Z | 9 | 12 | 13 | 13 | 16 | 16,5 | |
| FA | O1 | 9 | 10 | 11 | 11 | 13 | 15 | |
| | R | 3 | 4 | 5 | 5 | 5 | 5 | |
| | S1 | S1 | 51,5 | 66,5 | 82 | 84,5 | 106,5 | 130 |
| | | S (FLA) | 81,5 | 96 | 112 | 110,5 | - | 150 |
| | T1 | 100 | 115 | 130 | 130 | 165 | 215 | |
| | U | 120 | 140 | 160 | 160 | 200 | 250 | |
| | V | 80 | 95 | 110 | 110 | 130 | 180 | |
| | Z | 8 | 10 | 13,5 | 13,5 | 13 | 18 | |
| FD | O1 | 9 | 10 | 13 | 13 | 11,5 | 15 | |
| | R | 4 | 4 | 7 | 7 | 5 | 5 | |
| | S1 | S1 | 73,5 | 83,5 | 102 | 85 | 117,5 | 130 |
| | | S (FLD) | 103,5 | 113 | 132 | 111 | - | 150 |
| | T1 | 115 | 130 | 165 | 165 | 165 | 215 | |
| | U | 140 | 160 | 200 | 200 | 200 | 250 | |
| | V | 95 | 110 | 130 | 130 | 130 | 180 | |
| | Z | 11 | 11 | 13 | 13 | 13 | 18 | |

PRIX DES KITS BRIDES (A RAJOUTER AU PRIX DE BASE "FB")
PRIX EN EURO **PRIX EN EURO**

| | | | | | | |
|------------|--------------|--------------|--------------|--------------|--------------|--------------|
| FC | 13,33 | 18,67 | 24 | 28 | 44,33 | 58,33 |
| FL | 31,33 | 36,33 | 42 | 46 | 64 | 67,33 |
| FA | 16,33 | 18 | 30,67 | 30,67 | 66,67 | 70 |
| FLA | 34,33 | 36 | 47,33 | 47,33 | 56,67 | 76,67 |
| FD | 16,33 | 22,67 | 40 | 40 | 52,33 | 71,67 |
| FLD | 34,33 | 40,67 | 50,33 | 50,33 | 63,33 | 83,33 |